

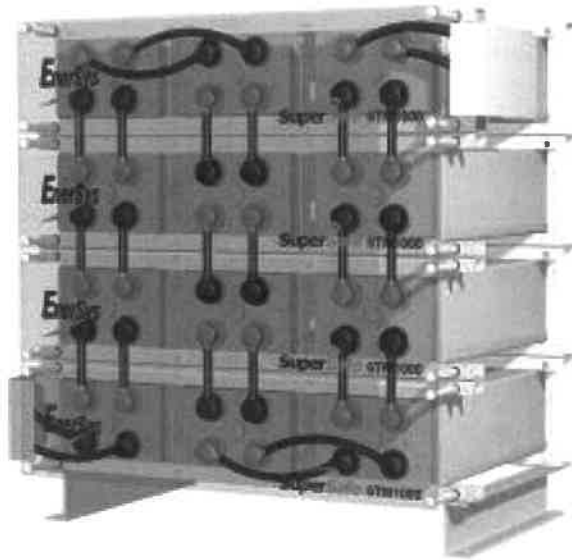

**BATTERY
INSTALLATION,
OPERATIONS AND
MAINTENANCE
MANUAL**



Power/Full Solutions

RESERVE
POWER

1. General Information	2
2. Safety Precautions	2
3. Technical Specifications	3
4. Receiving and Inspection	3
5. Storage and Freshening Charge	3
6. Battery Location	3
7. Unpacking and Module Assembly	4
8. Electrical Connections	5
9. Final Assembly Connections, Checks and Commissioning Charge	6
10. Charger Selection	7
11. Routine Operation	7
12. Routine Maintenance Procedures	7
13. Cell Removal / Replacement Procedure	8
14. Good Housekeeping	8
Appendix 'A'	8
Appendix 'B'	8
Appendix 'C'	9
MSDS	10
Battery Record Sheet	12

1. General Information

SuperSafe™ TM is a range of valve regulated sealed lead-acid batteries. The utilisation of gas recombination technology ensures that, in normal operation, the gas evolution is minimal and no topping-up is required during the service life of the battery. As a separate battery room is not necessary, SuperSafe TM is ideally installed alongside or in the same room as the equipment it supports.

2. Safety Precautions

Care for your safety



No smoking, no naked flames, no sparks



Electrical hazard



Electrolyte is corrosive



Shield eyes



Danger

All lead-acid batteries are potentially dangerous and particular care must be taken during their handling and installation.

Personnel undertaking this work must be provided with appropriate equipment to ensure their safety and in addition to exercising routine care and caution they should be additionally made aware of the following:

A) Sulphuric Acid - these batteries contain sulphuric acid which is corrosive and will cause burns and injury. In the event of contact with skin or eyes flush immediately with plenty of clean water and seek medical attention.

B) Explosive Gases - these batteries can give off explosive gasses. It is therefore important to keep sparks, flames and lighted cigarettes away from the battery.

Isolate the battery circuit before connecting or disconnecting to avoid sparks. Never lay tools or other metal objects on the modules to

IMPORTANT NOTE - IT IS MOST IMPORTANT TO READ AND FULLY UNDERSTAND THESE INSTRUCTIONS BEFORE COMMENCING THE UNPACKING AND INSTALLATION OF THE BATTERY. INSTALLATION SHOULD ONLY EVER BE UNDERTAKEN BY SUITABLY QUALIFIED PERSONNEL.



Clean all acid splash in eyes or on skin with plenty of clean water. Then seek medical help. Acid on clothing is to be washed with water.



Read instructions



Re-cycle scrap batteries. Contains lead



Risk of explosion or fire. Avoid any short circuit. Metallic parts under voltage on the battery, do not place tools or items on top of the battery.

avoid shorting. Ensure all connections are tight before switching on and only use insulated tools. Before working on a battery, metal personal effects such as watches, rings, bracelets etc, must be removed. Locations where batteries are kept and charged must be adequately ventilated.

C) Electric Shock and Burns - multi-cell systems attain high voltages and extreme caution must be taken to avoid serious shock and burns during installation.

D) SuperSafe TM cells are supplied filled and charged and are electrically live at all times so must be treated with great care. Even if a cell container and/or lid is damaged and weeping acid the cell is still capable of delivering high currents.

The following items are recommended to be available to ensure a safe and successful installation:

- a) Safety glasses with side shields or safety goggles
- b) Acid resistant gloves
- c) Protective rubber aprons
- d) Safety shoes
- e) Insulated tools - torque wrench and socket set
- f) Hammer drill - for floor anchor bolts
- g) Tape measure
- h) Chalk line
- j) Line cord

- k) Wooden or plastic straight edge
- l) Spirit level - plastic
- m) Cleaning materials - paper towels, wire wool, brass wire brush etc
- n) Lifting device of suitable capacity for the module weight
- p) A supply of clean water to rinse the eyes and/or skin in the event of any contact with electrolyte
- q) Spill containment and electrolyte neutralizing materials (e.g. dilute Sodium Hydroxide)

If the safety precautions and installation procedures are not fully understood clarification must be sought from your EnerSys® representative.

3. Technical Specifications

Battery Type	Nominal Voltage (V)	Nominal Capacity (Ah)		Nominal Dimensions*			Typical Weight ² (kg)	Short Circuit Current (A)	Internal Resistance (mΩ)
		10 hr rate to 1.80Vpc @ 25°C	8 hr rate to 1.75Vpc @ 77°F	Length (mm)	Depth ¹ (mm)	Height ¹ (mm)			
12TM-200	12	200	200	665	330	218	108	2746	4.370
12TM-300	12	300	300	893	330	218	158	3882	3.090
12TM-400	12	400	400	843	516	218	204	4050	2.950
12TM-500	12	500	500	957	516	218	239	5180	2.310
12TM-600	12	600	580	1071	516	218	281	6090	1.970
6TM-850	6	850	840	801	516	218	203	7980	0.750
6TM-1000	6	1000	1000	915	516	218	234	9275	0.640
6TM-1000A	6	1000	1000	801	584	218	235	7212	0.832
6TM-1100	6	1100	1080	972	516	218	255	9673	0.620
6TM-1200	6	1200	1200	915	584	218	269	8219	0.730
6TM-1300	6	1300	1300	972	584	218	287	8571	0.700
6TM-1360	6	1360	1360	1145	516	218	316	10453	0.570
6TM-1500	6	1500	1500	915	558	278	359	10733	0.560
6TM-1600	6	1600	1600	1145	584	218	369	11057	0.540
6TM-1700	6	1700	1640	972	558	278	386	11215	0.535
4TM-2000	4	2000	2000	791	558	278	307	17467	0.229
2TM-2600	2	2600	2600	676	584	218	196	17391	0.115
2TM-3000A	2	3000	3000	801	584	218	235	22222	0.090
2TM-3000	2	3000	3000	638	558	278	236	21978	0.091
2TM-3600	2	3600	3600	915	584	218	269	25000	0.080
2TM-4000	2	4000	4000	791	558	278	307	26667	0.075
2TM-4500	2	4500	4500	915	558	278	359	32780	0.061
2TM-5000	2	5000	4920	972	558	278	386	34483	0.058

Notes:

- (1) The depth shown in the table is for the module only. Add 86mm to obtain the overall depth including the front panel.
- (2) To calculate the total height of a battery stack multiply the module height by the number of modules in the stack and add 100mm for the base support except for the TM-1500, 1700, 2000, 3000, 4000, 4500 and 5000 modules where 120mm must be added.
- (3) The typical weight of the module excludes the connectors, terminal plates, front panels and base support.
- (4) SuperSafe™ TM batteries are designed for horizontal installation only.
- (5) The excellent flexibility afforded by the modular construction design provides for further combinations of capacity, voltage or footprint in addition to those illustrated in the above tabulation, eg 2TM-3200, 2TM-4800, 4TM-1000, 4TM-1700 etc.

4. Receiving and Inspection

Upon receipt of a delivery each case should be inspected for damage at the time of unloading. Should any damage be identified it should be further investigated then noted down and reported in writing to both the carrier and your EnerSys® representative. Remove the lids from the packing cases and check the cells and hardware against the packing/material list. Any missing items should be notified immediately in writing to both the carrier and your EnerSys representative. EnerSys is not responsible for damage or missing items not reported as above. The terminal voltage of each cell should be checked to ensure that none are below 2.12 volts. Any low voltage readings should be reported to your EnerSys representative immediately.

5. Storage and Freshening Charge

Any cells/modules that are not to be installed immediately should be put into storage in a cool, clean, dry, well ventilated area. Recommended storage temperature range is -18°C (0°F) to 32°C (90°F).

Cells are supplied filled and charged from the factory. Lead-acid cells are subject to self discharge. If cells are to be stored for several months, they will require a freshening charge at six monthly intervals following receipt to keep them in good condition. The initial "freshening charge-by date" is clearly

shown on the label attached to each packing case. The freshening charge should be completed with the lids removed from the packing cases in an adequately ventilated area. As with normal float charge operation, the freshening charge should only be completed using a constant potential charger. The correct float voltage can be obtained from Appendix "A" and should be applied for 48 hours. A record should be kept of all freshening charges applied during any prolonged storage period to maintain the warranty.

If the cells are to be stored at high temperatures for prolonged periods you should consult your EnerSys representative for further advice on freshening charging.

6. Battery Location

The battery location should have an adequately strong level floor and be clean, cool and dry with good lighting and ventilation. It is recommended that a minimum free space of 900mm (36 inch) is provided in front of the battery to allow for service and inspection. As a separate battery room is not required, the best location for the battery is in the room with its associated power supplies and equipment.

7. Unpacking and Module Assembly

WARNING - THESE BATTERIES ARE HEAVY. SERIOUS INJURY COULD RESULT FROM MISHANDLING. DO NOT ATTEMPT TO LIFT THEM WITHOUT MECHANICAL ASSISTANCE. DO NOT WORK ALONE.

A typical battery installation will comprise one case of accessories and a number of associated cases each containing two modules. Throughout the installation procedure the correct hardware may be selected in consultation with the assembly drawing and the correct torque value from Appendix "B".

- a) remove the lid of the battery accessories case and take out the different item packs, see Fig 1. Consult the battery assembly drawing to become familiar with the different accessory items and the polarity orientation of the finally assembled modules.

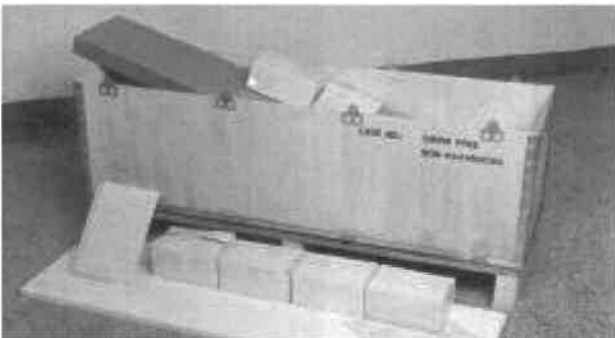

Figure 1: Battery accessories case

- b) using the assembly drawing, the tape measure and the chalk line, mark the intended position of the battery on the floor.
- c) take the mounting base channels, place them in position and when required anchor them to the floor. NOTE - it is the responsibility of the installer to comply with the relevant building codes and local regulations and to provide the appropriate anchoring materials.
- d) remove the lid and four sides from a case of modules. Note that for security during transportation the two modules are bolted both together AND to the base pallet of the packing case, see Fig 2. Remove all the transit bolts to allow the modules to be lifted clear of the pallet base and onto the floor.

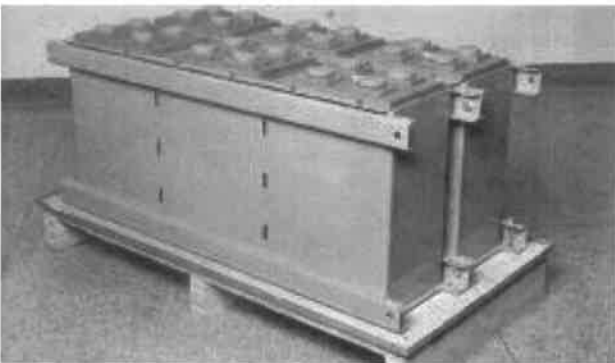

Figure 2: The modules bolted together and to the pallet using transit bolts

- e) take one of the two lifting strap/hook assemblies provided and attach it to a module. DO NOT USE THE HOLE IN THE SHORT SIDE OF THE U CHANNEL - USE ONLY THE HOLE DEPICTED IN FIG 3 .



Figure 3: Lifting strap/hook attached to a module

- f) using the lifting device raise the module just clear of the pallet, see Fig 4 and place it vertically on the floor.

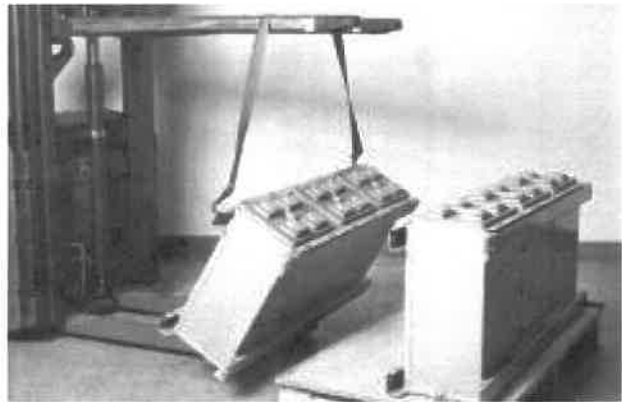

Figure 4: Lifting the module clear of the pallet

- g) taking note of the polarity orientation of the module again use one of the lifting strap/hook assemblies and the lifting device to lay the module horizontally on the floor.
- h) attach the two lifting strap/hook assemblies provided to the module, see Fig 5, and using the lifting device position the module onto the mounting base channels. Use of the locating rod may simplify the alignment of the holes. Bolt the module to the base channels using the hardware provided.



Figure 5: Positioning the module onto the base channels

- i) repeat E, F and G.
- j) attach the two lifting strap/hook assemblies provided to the module and using the lifting device position the module on top of the first and bolt them together using the hardware provided.
- k) repeat D, E etc. until the modules have been fully assembled as shown on the assembly drawing. Carry out a final check to ensure that the modules are correctly orientated with respect to polarity.
- l) discard the lifting strap/hooks - they are not intended for long term use.

8. Electrical Connections

WARNING -
BEFORE YOU START WORK - MAKE CERTAIN YOU ARE FAMILIAR WITH THE POLARITY SEQUENCE OF THE CONNECTIONS. SOME SYSTEMS MAY BE CONNECTED SO THAT THE CELL CASE AND/OR THE RACK ARE LIVE RELATIVE TO THE TERMINALS.

INADVERTANT SHORT-CIRCUIT BETWEEN THE TERMINALS AND BATTERY CASE WITH A METAL OBJECT SUCH AS A CONNECTOR OR TOOL COULD CAUSE SERIOUS INJURY OR DEATH.

8.1 Inter-tier and inter-row Connections.

- a) before despatch from the factory each individual cell terminal is cleaned and coated with a layer of non-oxide grease.
- b) all the cell terminals have their polarity clearly marked by either a RED ring to denote a positive terminal or a BLACK ring to denote a negative terminal.
- c) the connector contact surfaces should be cleaned and a thin layer of non-oxide grease applied.
- d) taking note of the polarity fit all the inter-tier and inter-row connectors as shown on the battery assembly drawing using the hardware provided. Tighten them in accordance with the torque limit information in Appendix "B".

8.2 Main Terminal Assembly

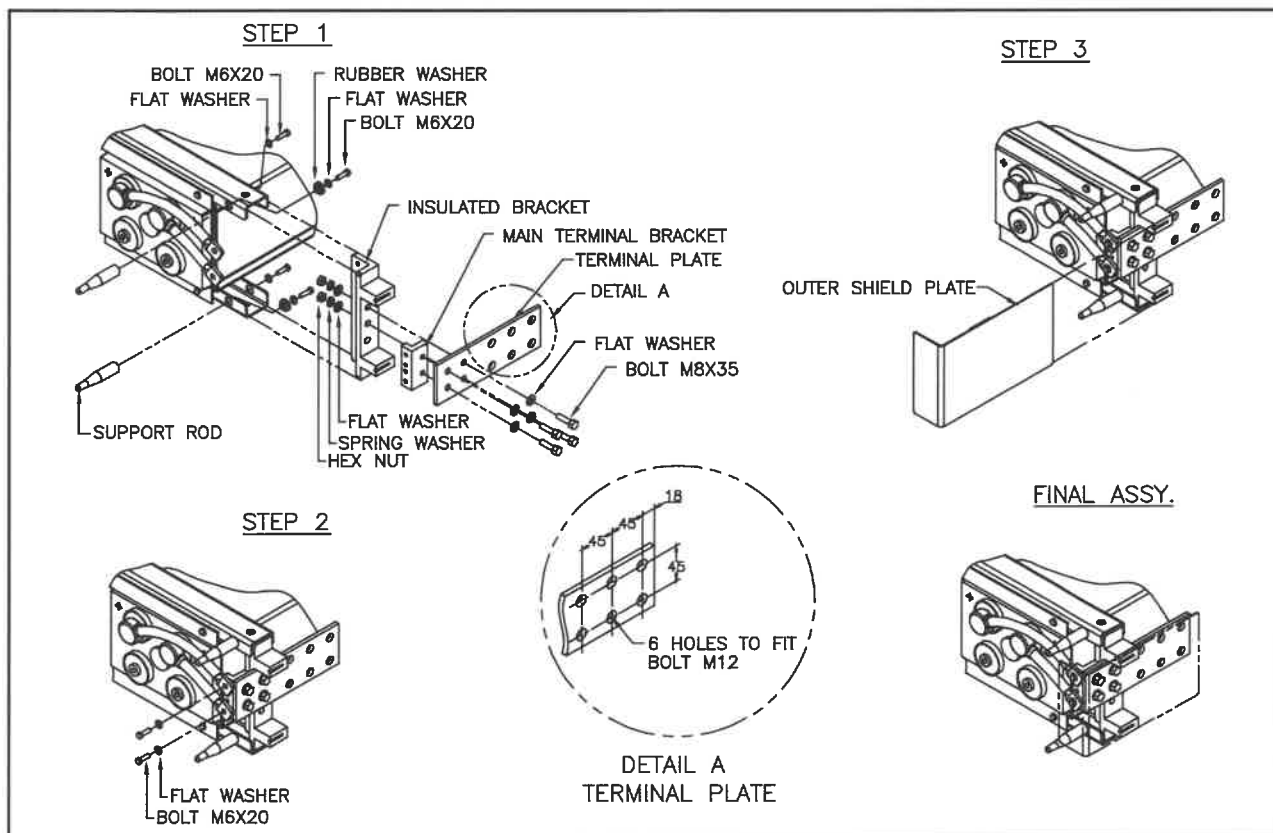

Figure 6: Main terminal assembly detail

- a) fit the inner-shield to the module.
- b) bolt the terminal plate insulating bracket to the frame of the steel module.

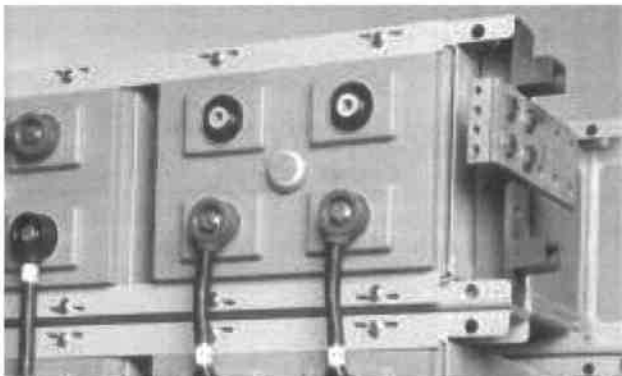

Figure 7: Main terminal bracket and terminal plate bolted to the mounting bracket

- c) bolt the main terminal bracket and terminal plate to the mounting bracket, see Fig 7.

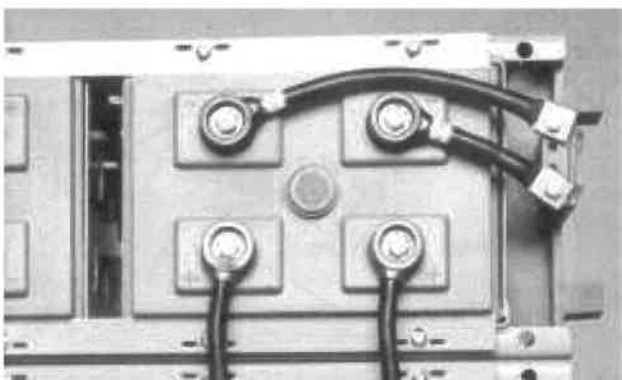

Figure 8: Take-off connectors between cell terminal and main terminal plate

- d) fit the take-off connector(s) between the cell terminal(s) and the main terminal plate, see Fig 8.
- e) where cable connectors are used, fit the insulating lids to each of the terminals.

9. Final Assembly Connections, Checks and Commissioning Charge

- a) in order to identify each cell within the battery, a set of self adhesive numbered labels are supplied for fixing to the cell lids. It is normal practice to identify the positive end cell as No.1 with the remaining cells being numbered consecutively following the path of the electrical connections throughout the battery.
- b) once all the connections have been tightened to the correct torque and with the battery on open circuit, read and record the individual cell and the total battery voltage using a DC voltmeter. The total battery voltage should be approximately equal to the number of cells multiplied by the reading of one cell. If it is less, re-check the connections for the correct polarity.
- c) fit the four support rods (see illustration Fig 6) to each of the module frames.

The assembly of the battery is now completed to the stage where external electrical connections can be made to commence the Commissioning Charge. The connections between the battery and it's associated charger are made at the main terminal plates. Ensure that the charger POSITIVE lead is connected TO the main battery POSITIVE terminal and that the charger NEGATIVE lead is connected TO the main battery NEGATIVE terminal. Care should be taken in selecting the size of these connecting cables to optimise the voltage drop between the charger output terminals and the main battery terminals.

Where battery strings are to be connected in parallel, this voltage drop should be equalised in each of the circuits to avoid imbalances in the charging/discharging circuits of the different strings which may result in damage to the battery system and a reduction in operating life.

Once these connections have been made:

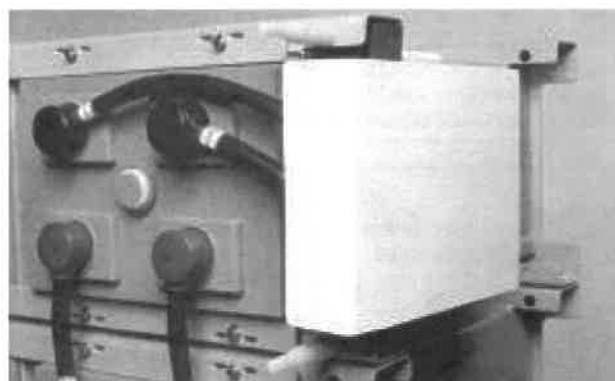

Figure 9: Outer shield attached to the main terminal take-offs

- d) attach the outer shield to both the positive and negative main terminal take-offs, see Fig 9.

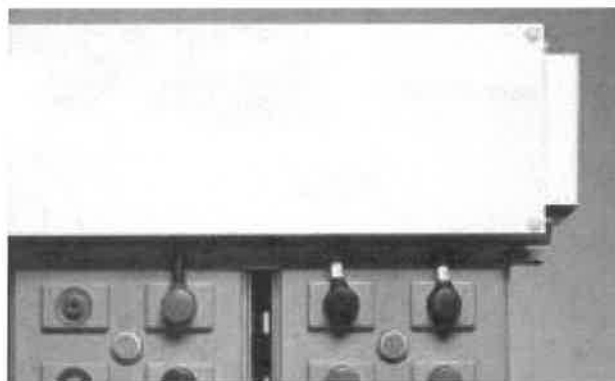

Figure 10: Front panel attached to the four support rods

- e) attach a front panel to the four support rods on each of the modules with the connector sheaths provided, see Fig 10.
- f) with NO LOAD attached to the system, switch on the charger and record readings of cell voltage and charge current to form the very important Commissioning Charge Record for future reference. It is intended that the example Battery Record Sheet shown on page 12 of this manual be photocopied and used for recording purposes.
- g) continue the charge until the current flow into the battery has fallen to a minimum and remained constant for 3 consecutive hourly readings.

- h) if the battery is to be immediately put into service, continue the commissioning charge for a minimum total continuous time of 72 hours.
- i) if the battery is to be subjected to a site acceptance test before being put into service, continue the commissioning charge for a minimum total continuous time of 144 hours.

N.B. when a site acceptance test is required, it must be completed following the commissioning charge BEFORE any operating load is introduced into the system.

Upon completion of the commissioning charge or recharge following a site acceptance test, the load circuit may be introduced into the system and the battery maintained thereafter in the normal operating "float charge" mode.

10. Charger Selection

These batteries are designed to be connected in parallel with a load that is normally powered by a charger. The charger MUST be of the constant potential type with a characteristic to give an applied charging voltage, at the main battery terminals, equivalent to a minimum of 2.25 volts per cell and a maximum 2.28 volts per cell at an ambient temperature of 25°C (77°F). For further details of the float voltage to be applied to those installations where the mean operating temperature is other than 25°C (77°F), consult Appendix "A".

For optimum charge efficiency the MAXIMUM charge current available to the battery should be limited to 8% C₈ capacity expressed in amps eg 80.64 amps for the TM-1000, 124.80 amps for the TM-1500, with a MINIMUM charge current output equivalent to 5% C₈ capacity expressed in amps eg 50.4 amps for the TM-1000. 78 amps for the TM -1500.

The battery will accept, without damage, higher values of charge current provided that the applied charge voltage does not exceed the recommended float charge level.

The ripple content of the charging current affects the life of a battery. The rms value of the a.c. component of the charging current (fundamental and harmonic) must not exceed 0.10 C₈ (Amps).

Transient and other ripple type voltage excursions can be accommodated provided that, with the battery disconnected, the system peak to peak voltage including regulation limits falls within ±2.5% of the recommended float voltage.

11. Routine Operation

11.1 Charging

The normal operating procedure is for the battery to be subject to a "float charge" in parallel with the charger as described above.

It is important that the level of the applied voltage is adjusted in accordance with the value(s) given in Appendix "A". Select a temperature that most nearly represents the actual mean operating temperature of the particular installation in order to optimise the battery performance.

It is important that the applied voltage does not fall below the minimum value shown.

Equally, any excursion of "battery voltage" above the recommended float charge voltage for more than one minute should either trigger an alarm or cause immediate termination of the charge (except under controlled elevated voltage charging, see 11.2).

It is recommended that batteries should be recharged within 24 hours following a discharge.

It is recommended that this level of float voltage also be used for:

- a) the freshening charge procedure - see Section 5,
- b) the commissioning charge procedure - see Section 9
- c) for the normal recharging of the battery following a discharge in order to minimise any possibility of overcharge.

11.2 Faster Charging

Recharge times can be reduced by increasing the level of the applied charging voltage.

The MAXIMUM applied voltage should never exceed that equivalent to 2.4 volts per cell at 25°C (77°F) AND when using this charge regime:

- a) reduced service life will result from frequent use.
- b) the available charging current MUST be limited to 8% C₈ capacity expressed in amps.
- c) the charge MUST be terminated when the charge current reaches a constant value.
- d) this elevated applied charging voltage may be used for a MAXIMUM of 12 hours.

IF THIS METHOD IS SELECTED IT IS VITAL THAT THE CHARGER IS RE-SET TO THE "NORMAL" FLOAT VOLTAGE SETTING AT THE END OF USE TO AVOID SERIOUS DAMAGE TO THE BATTERY.

11.3 Discharging

The minimum average voltage per cell should not be reduced to below 1.60V for longer than 2 minutes on a battery designed for a standby time of up to 1 hour or for longer than 5 minutes on a battery designed for a standby time in excess of one hour. It is recommended that a low voltage disconnect feature is included in the system to ensure compliance with the above.

N.B. momentary dips in voltage below 1.6Vpc as experienced in switchgear closing operations are not detrimental.

11.4 Operating Temperature

The nominal operating temperature for a lead acid battery is 20-25°C (68-77°F) Operating at temperatures above 25°C (77°F) will reduce the operating life of a battery.

12. Routine Maintenance Procedures

12.1 Three Monthly Inspection.

- a) complete a visual check of the overall installation looking for signs of electrolyte leakage and corrosion around the terminal posts.
- b) check and record the overall applied voltage across the battery and adjust as necessary.
- c) record the individual cell voltages on the battery record sheet under float charge and compare them with the last set looking for any adverse trends in the reading of any individual cell(s).

12.2 Six Monthly Inspection

- a) repeat the three monthly inspection.
- b) if any cell is continuing to show adverse trends in it's voltage reading contact your EnerSys® representative.

12.3 Yearly Inspection

- a) repeat the six monthly inspection.
- b) check the torque settings of the various nuts and bolts correcting as necessary.

12.4 General

It is considered as good practice to record details of emergency and accidental discharges. During the re-charge, record the voltage at the terminals of the battery and the value of the charge current, if possible, towards the end of the charge.

13. Cell Removal / Replacement Procedure

In the event of it becoming necessary to replace any single cell within a battery/module then the following procedure should be adopted having first contacted your local EnerSys® representative and obtained the necessary tools:

- a) turn off the charger and disconnect it from the battery.
- b) remove the front panel from the module containing the cell to be replaced.
- c) disconnect the inter-cell connectors from the cell.
- d) remove the cell retainer bar from the top and bottom of the module.
- e) flip the cover off the valve assembly.
- f) using the key provided by your EnerSys representative slowly undo the flame arrestor/valve assembly just sufficiently to allow the gas to escape releasing the positive pressure from within the cell casing and then immediately re-tighten the flame arrestor/valve assembly.
- g) screw the tools obtained from your local EnerSys representative into the terminals of the cell and pull it from the steel module onto a lift truck or suitably positioned support assembly.
- h) push the fully charged replacement cell into the steel module, re-fit the cell retaining bars, the inter-cell connectors and the front panel. Re-connect the charger to the battery system and switch it on.

14. Good Housekeeping

- a) keep the battery and it's surrounding area clean and dry.
- b) keep the connectors (solid), terminals and terminal bolted connections covered with the non-oxide grease supplied.
- c) occasionally, carefully wipe any dust or other deposits from the modules with a soft cotton cloth dampened with clean water. SCOURING CLOTHS AND CLEANING FLUIDS/SOLVENTS SHOULD NEVER BE USED TO CLEAN THE BATTERY TO PREVENT ANY POSSIBLE DAMAGE TO THE PLASTICS.

APPENDIX 'A'

Recommended applied Float Voltage

Temperature	Voltage per cell
0°C (32°F)	2.33 - 2.36V
10°C (50°F)	2.30 - 2.33V
20°C (68°F)	2.27 - 2.30V
25°C (77°F)	2.25 - 2.28V
30°C (86°F)	2.24 - 2.27V
35°C (95°F)	2.22 - 2.25V
40°C (104°F)	2.21 - 2.24V

APPENDIX 'B'

Torque Settings

Connection Type		Torque Nm (lbf in)
Stainless steel bolt (Terminal)	M6	6 (53)
Stainless steel bolt (Terminal)	M8	10 (88)
Stainless steel bolt (Terminal)	M10	15 (132)
Stainless steel bolt (Terminal plate to Insulated bracket)	M8	10 (88)
Stainless steel bolt (External cable connection to terminal plate)	M12	16 (141)
Zinc galvanised bolt for connecting base and module	M10	22 (194)
Zinc galvanised bolt for inter-module connections	M10	22 (194)

APPENDIX 'C'

Table: Floor Loading / Anchor Detail (mm)

Battery Type	A	B	C	D
12TM-200	615±0.5	222.6±0.5	59	50+2
12TM-300	843±0.5	222.6±0.5	59	50+2
12TM-400				
12TM-500	907±0.5	406.4±0.5	60	50+2
12TM-600				
6TM-850				
6TM-1000	865±0.5	406.4±0.5	60	50+2
6TM-1000A				
6TM-1100				
6TM-1200				
6TM1300				

Battery Type	A	B	C	D
6TM-1360				
6TM-1500	1097±0.5	318±0.5	71	50+2
6TM-1600				
6TM-1700				
4TM-2000				
2TM2600				
2TM-3000A				
2TM-3000				
2TM-3600				
2TM-4000				
2TM-4500				
2TM-5000				

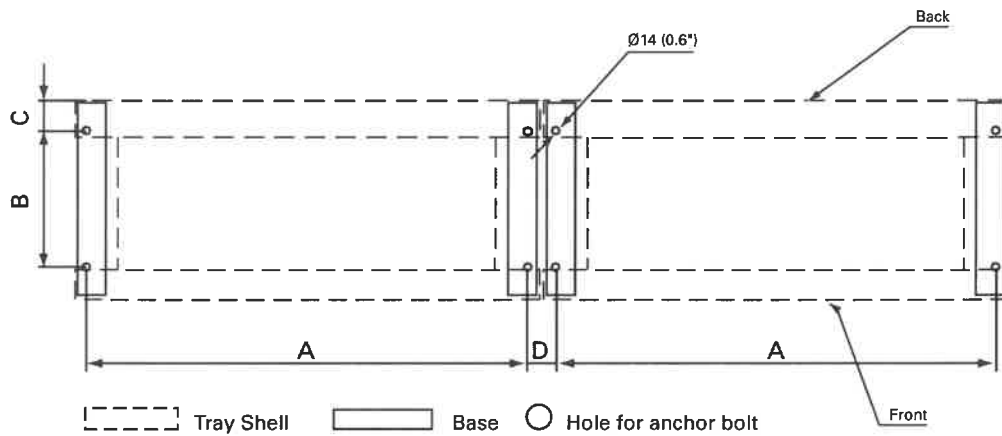

Battery Type	Dimension of each foot (mm x mm)	Weight per Module Incl. accessories (kg)
12TM-200	318 x 48	107
12TM-300	318 x 48	155
12TM-400		
12TM-500	503 x 48	231
12TM-600		
6TM-850		
6TM-1000	503 x 48	237
6TM-1000A		
6TM-1100		
6TM-1200		
6TM1300		

Battery Type	Dimension of each foot (mm x mm)	Weight per Module Incl. accessories (kg)
6TM-1360		
6TM-1500	460 x 63	380
6TM-1600		
6TM-1700		
4TM-2000		
2TM2600		
2TM-3000A		
2TM-3000		
2TM-3600		
2TM-4000		
2TM-4500		
2TM-5000		

MATERIAL SAFETY DATA SHEET (MSDS)

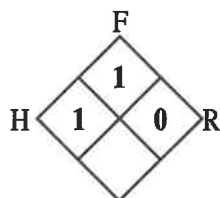

NFPA 704 RATING



INFORMATION ONLY - Please read Section IX

SECTION I - Product and Manufacturer Identity

Product Identity:

Revision Date: March 2001

Sealed Lead Battery
SuperSafe™ TM

Manufacturer's Name and Address:

EnerSys
No. 49, Yan Shan Road, Shekou Industrial Zone
Shenzhen, 518066, P.R. China

Telephone Number:
(China) +86 755 2689 3639
(Europe) +32(0)2 247 94 47
(US) 610 208 1991

SECTION II - Ingredients

Hazardous Components	CAS #	OSHA PEL-TWA	% (By weight)
Lead	7439-92-1	0.05 mg/m ³	45-60 %
Sulphuric Acid Electrolyte	7664-93-9	1.0 mg/m ³	15-20 %
Non-hazardous Materials	N/A	N/A	5-10 %
Lead dioxide	1309-60-0	0.05 mg/m ³	15-25 %

SECTION III - Physical/Chemical Characteristics

Boiling Point - N/A
Vapor Pressure (mm Hg.) - N/A
Solubility in Water - N/A

Specific Gravity (H₂O=1) - NA
Melting Point - N/A
Appearance & Color - N/A

SECTION IV - Fire & Explosion Hazard Data

Flash Point (Method Used): N/A Flammable Limits: N/A LEL: N/A UEL: N/A

Extinguishing Media: Multipurpose Dry chemical, CO₂ or Water spray.

Special Fire Fighting Procedures: Cool Battery exterior to prevent rupture. Acid mists and vapors in a fire are toxic and corrosive.

Unusual Fire and Explosion Hazards: Hydrogen gas may be produced and may explode if ignited. Remove all sources of ignition.

SECTION V- Reactivity Data

Conditions to Avoid: Avoid short circuit. Avoid over-charging. Use only approved charging methods.
Do not charge in gas tight containers. Avoid puncturing battery case.

SECTION VI - Health Hazard Data

Routes of Entry: N/A

Emergency & First Aid Procedures:

Health Hazards (Acute & Chronic): N/A

Battery contains acid electrolyte which is absorbed into the separator material. If battery case is punctured, completely flush any released material from skin or eyes with water. If eyes are affected, seek medical attention.

SECTION VII - Precautions for Safe Handling & Use

Steps to be taken in case material is released or spilled:

Waste Disposal Method:

Avoid contact with acid materials. Use soda ash or lime to neutralize. Flush with water.

Dispose of in accordance with Local Regulations. Do not incinerate. Batteries should be shipped to a reclamation facility for recovery of the metal and plastic components as the proper method of waste management. Contact distributor for appropriate product return procedures.

SECTION VIII - Control Measures - Not Applicable

SECTION IX - Additional Information

The Supersafe™ sealed lead acid battery is determined to be an "article" according to the OSHA Hazard Communication Standard and is thereby excluded from any requirements of the standard. The Material Safety Data Sheet is therefore supplied for informational purposes only.

The information and recommendations contained herein have been compiled from sources believed to be reliable and represent current opinion on the subject. No warranty, guarantee, or representation is made by EnerSys® as to the absolute correctness or sufficiency of any representation contained herein EnerSys assumes no responsibility in connection therewith, nor can it be assumed that all acceptable safety measures are contained herein, or that additional measures may not be required under particular or exceptional conditions or circumstances.

N/A or Not Applicable - Not applicable for finished product used in normal conditions.

Battery Record Sheet

Works Order No:	Customer Ref:	
Installed At:		Battery Title:
No. of Cells:	Type	Date Installed:
Total battery voltage across terminals:	V	Ambient Temperature: °C
Battery Charging Current:	A	Average Vpc:
Remarks/Recommendations:		
Engineer in Charge:	Date of Service:	

Individual cell readings

Cell No.	Serial No	Volts per Cell
1		
2		
3		
4		
5		
6		
7		
8		
9		
10		
11		
12		
13		
14		
15		
16		
17		
18		
19		
20		

Cell No.	Serial No	Volts per Cell
21		
22		
23		
24		
25		
26		
27		
28		
29		
30		
31		
32		
33		
34		
35		
36		
37		
38		
39		
40		

Cell No.	Serial No	Volts per Cell
41		
42		
43		
44		
45		
46		
47		
48		
49		
50		
51		
52		
53		
54		
55		
56		
57		
58		
59		
60		

Distributed in New Zealand by DCPower Batteries



187 John F Kennedy Drive
 Palmerston North, 4414, New Zealand
 Phone +64 6 359 0834
 www.dcpower.co.nz|info@dcpower.co.nz

