

Pallet Pro™ On-Board Power System and
12 Volt Group 24/27 and 6 Volt Group 27
Deep Cycle Bloc Batteries

Element® Pallet Pro™ On-Board Power System

Application

The Pallet Pro is an integrated valve regulated lead acid battery and charging system designed for 24 volt electric walkie pallet trucks with loading capacities of up to 4,000 pounds.

System Design

GNB® Industrial Power's Pallet Pro houses a "smart" SCR charger complete with auto stop/start capabilities and four, 6-volt Element deep cycle bloc batteries connected in series to provide a 24 volt system with up to 25% more capacity, at the 6 hour rate, than competitively published rates.

Less Maintenance

Element batteries mean reduced maintenance. Most of the expense, time and safety concerns typically associated with conventional flooded battery maintenance are reduced under normal operating conditions, including cell watering, acid equalization, acid spills, corrosion and waste treatment systems.



Pallet Pro Design

The Element deep cycle bloc batteries used in the Pallet Pro incorporate the proven Absolyte® technology used in larger industrial Element cells for just a fraction of the cost. Element batteries have a more robust design with lower internal resistance than traditional flooded batteries, providing higher voltage.

Battery Warranty

The Pallet Pro system is warranted for a full year. For more specific information, see Limited Warranty GB3853.

Automatic On-Board Charger

Because the on-board charger used with the Pallet Pro is fully automatic, operator guesswork is eliminated. Unlike other chargers, this charger uses the precise "I-E-I" charge profile to correctly determine the proper recharge time required.

Charging begins with a constant 25 amp start rate until the batteries reach the appropriate gassing voltage. At this point, the charge adjusts to a constant voltage stage to minimize gassing, finishes off with a constant current to ensure a quick and complete charge, and finally shuts down automatically when the batteries are fully recharged. International versions are available for 220 VAC, 50 Hz areas.

Opportunity Charging Benefits

With the Pallet Pro, battery charging is simple and efficient, offering operators freedom from the charging limitations of conventional flooded batteries. Operators can take full advantage of extended breaks or downtime between shifts to opportunity charge their Pallet Pro which translates into better use of operator time and increased productivity!

Optimum Depth of Discharge for opportunity charging is between 30% - 70%. A minimum charge time of 1/2 hour and an additional cool down period is recommended for best results. Contact your local GNB sales representative for more information on appropriate procedures when incorporating opportunity charging into your battery program.



Pallet Pro™ On-Board Power System

1. Element Valve Regulated Batteries

6 Volt, Element bloc batteries reduce the hazards and mess associated with typical flooded battery maintenance and allows opportunity charging benefits.
VIRTUALLY NO HYDROGEN GASSING AND MINIMAL MAINTENANCE

2. Metal Bracket Design

Additional shock absorption to minimize both horizontal and vertical battery movement
BATTERIES ARE SECURED INSIDE THE TRAY TO HELP ELIMINATE POTENTIAL VIBRATION DAMAGE.

3. Built-In Circuit Breaker

Simple, accessible re-set switch provides the operator with a quick repair solution after a power surge.
REDUCES DOWNTIME FOR CHARGER SERVICE DUE TO FUSE REPLACEMENT

4. 10 Gauge Steel Housing

Durable, 100% powder coated tray.
HELPS ENSURE A LONGER LASTING MORE DURABLE TRAY UNDER A VARIETY OF CONDITIONS

5. Automatic Start/Stop and LED Display

Eliminates operator guesswork on required recharge time and charging status
HELPS ENSURE SAFE, SIMPLE AND RELIABLE OPERATION. HELPS PROTECT AGAINST HARMFUL EFFECTS OF OVER- AND UNDER-CHARGING

6. Grommet Around Cable Exits

Plastic grommet protects against cable chafing after daily usage.
HELPS ENSURE SAFER OPERATION.

7. Easy to Store 7 foot AC Cord

Charge the system anywhere there is a 110/120 volt, 15 amp AC outlet. International chargers are available for 220 VAC 50 Hz areas.
FOR EASY, CONVENIENT RECHARGES.

8. Gray SB175 connector and 35" lead length.

Other connectors are available upon request.

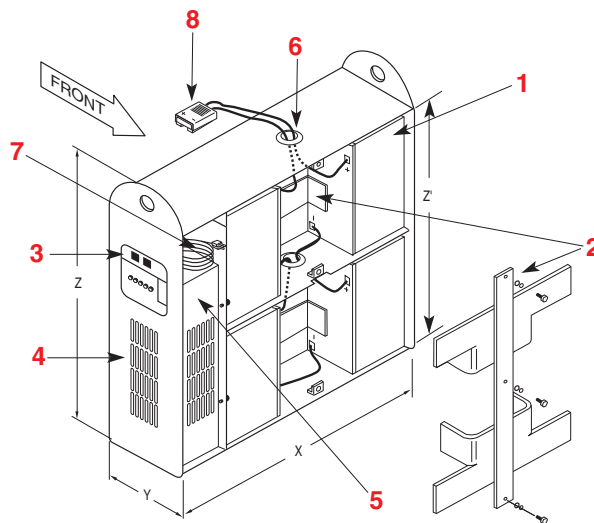

Pallet Pro Specifications

Battery Part Number	Battery System Voltage	Capacity 6 Hour Rate		Battery Dimensions inches/mm				Nominal Weight ¹ lbs./kg
		AMP-HRS	KWH	X LGTH	Y WDT	Z ¹ HT	Z HT	
M90004S24CHPA	24	195	4.6	27.30 693	8.69 221	24.45 621	26.45 672	400 182
M90004S24CHPB	24	195	4.6	29.00 737	7.50 191	24.45 621	26.45 672	400 182
M90004S24CHPC	24	195	4.6	25.50 648	8.69 221	24.45 621	26.16 664	400 182
M90004S24CHPX	24	195	4.6	27.30 693	7.50 191	24.45 621	26.45 672	400 182

Pallet Pro trays are designed to allow for optional hold-down features. Contact your OEM for recommended components and prices.
¹35" lead length cable assembly. ¹ +/- 5%

Element® 12 Volt Group 24/27 and 6 Volt Group 27 Deep Cycle Bloc Batteries

Application

Valve-Regulated deep cycle bloc batteries designed for use in Pallet Pro systems, maintenance (scissor) lifts, wheel chairs, neighborhood electric vehicles (NEV's), golf carts, personnel carriers, and other small powered electric vehicles.

These BCI Group 24 and Group 27 size batteries are engineered to provide full shift performance to an 80% depth of discharge (D.O.D.), equal to 1.90 volts per cell. Tests performed to measure battery life expectancy have resulted in battery life greater than 300 cycles.

Battery Warranty

Element Group 24 and Group 27 deep cycle bloc batteries are warranted for 90 days. When purchased as a replacement for a Pallet Pro system, GNB Industrial Power will honor the warranty remaining on the original system if longer than 90 days. Contact your local GNB Sales Representative for warranty details.

Less Maintenance

Element valve regulated deep cycle bloc batteries mean reduced maintenance. Most of the expense, time and safety concerns typically associated with conventional flooded battery maintenance are reduced under normal operating conditions, including cell watering, acid equalization, acid spills, corrosion and waste treatment systems.

“Designed In” Quality Manufacturing Made in the USA.

Quality manufacturing processes for the Element series of deep cycle bloc batteries incorporate some of the industry's most advanced technologies including: 100% automated helium leak detection system, computer controlled “fill by weight” acid filler, and capacity testing of every unit.

Required Charging Profile

Element batteries require a specific “I-E-I” (constant current-constant voltage-constant current) recharge profile be used

to maximize battery life. Use of a charger with the incorrect recharge profile will significantly shorten your battery's life and void your battery warranty. For more information contact your local GNB Sales Representative.

The following is the recommended charging algorithm for the Element deep cycle bloc batteries at 25°C (77°F):

Step 1. Charge at 13 Amps per 100 Amp-hours to 2.37 volts per cell.

Step 2. Charge at 2.37 volts per cell for 3 hours.

Step 3. Charge at 2.5 Amps per 100 Amp-hours for 2 hours and a maximum voltage of 2.80 volts per cell.

For temperatures other than 25°C (77°F), the following formula can be used to determine the correct charge voltage

$$V \text{ corrected} = V_{25^{\circ}\text{C}} - [(T \text{ actual} - 25^{\circ}\text{C}) * (0.0055 \text{ V}/^{\circ}\text{C})] \text{ or}$$

$$V \text{ corrected} = V_{77^{\circ}\text{F}} - [(T \text{ actual} - 77^{\circ}\text{F}) * (0.003 \text{ V}/^{\circ}\text{F})]$$

The minimum corrected voltage for charging is 2.25 volts per cell and the maximum corrected voltage for charging is 2.50 volts per cell.

Innovative Technology

Element deep cycle bloc batteries incorporate the proven Absolyte® technology used in larger industrial Element cells.

Because of the Element design, there is virtually no gassing while charging under normal operating conditions, eliminating the need for special ventilation and a dedicated charging room.

Fully Recyclable

GNB takes pride in its commitment to a better environment. Its Total Battery Management program, an integrated approach to manufacturing, distributing and recycling of lead acid batteries, has been developed to help ensure a safe and responsible life cycle for all of its products.

Element Deep Cycle Bloc Battery Specifications

Battery Part Number	Battery DC Volts	20 Hour Rate		Capacity 6 Hour Rate		3 Hour Rate		Battery Dimensions (inches/mm)			Nominal Weight ² (lbs./kg)
		AMP-HRS	KWH	AMP-HRS	KWH	AMP-HRS	KWH	X LGTH	Y WPTH	Z' HT ¹	
M83CHP12V24	12	92	1.10	80	0.94	70	0.82	10.25	6.85	8.80	60
								260	174	224	27.2
M83CHP12V27	12	110	1.30	95	1.10	85	1.00	12.05	6.85	8.80	70.4
								306	174	224	31.9
M83CHP06V27	6	220	1.30	195	1.15	175	1.03	12.05	6.85	8.80	75
								306	174	224	34

¹ Height to top of post. Bolt, washer and connector typically increases height by 0.450 in. (11mm)

² Weight +/- 1kg. +/-2.2lbs

Terminal Position

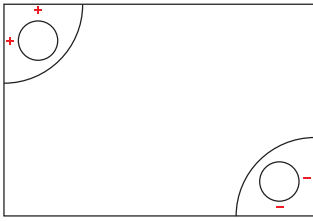

6 Volt Unit

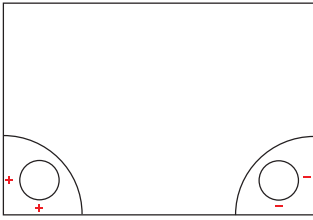

12 Volt Unit

Element Deep Cycle Bloc Battery Design

- 1. Absorbed Glass Mat Separator**
Retains the electrolyte in a highly porous mat to help prevent leakage and promote efficient recombination. **NO WATERING IS REQUIRED** under normal operating conditions.
- 2. M6 Bolts, Brass Inserts and Bolt-On Connectors**
Reduced electrical resistance and increased voltage.
- 3. Self-Resealing Pressure Relief Valve & Flash Arrestor**
Relief valves control internal pressure for efficient recombination during recharge. The safety vent opening pressure is 2.5 - 5.5 psi. Anti-flame design prevents sparks from entering the cell.
- 4. Reinforced Polypropylene Container and Cover**
Side rib pattern for extra support.
- 5. Lead Calcium Alloy Negative Plate**

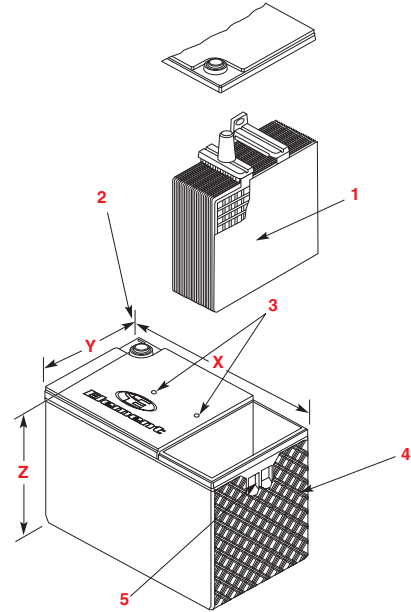

NOTE:

Packaged complete with SS-316 bolts and washers.

Weekly Self-Discharge 0.5 - 1.0%

Design or specifications subject to change without notice

Element M83CHP12V24 Discharge Characteristics [At 25°C (77°F)]

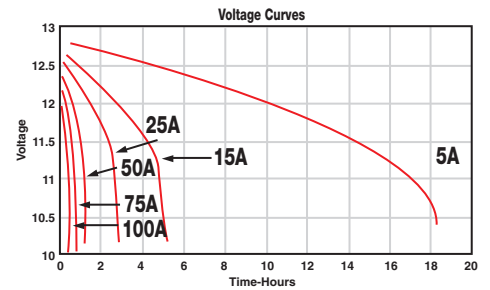
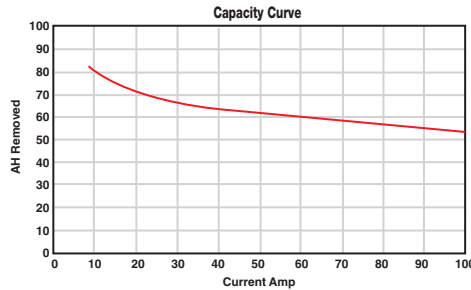

Element M83CHP12V27 Discharge Characteristics [At 25°C (77°F)]

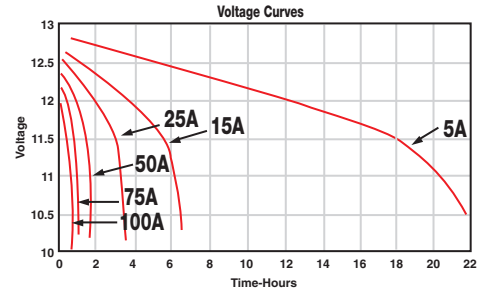
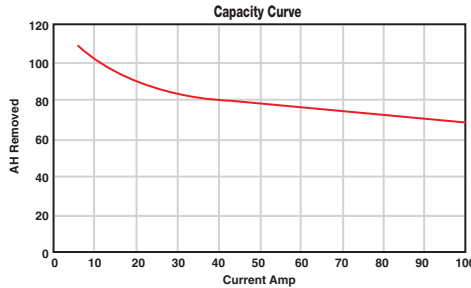

Element M83CHP6V27 Discharge Characteristics [At 25°C (77°F)]

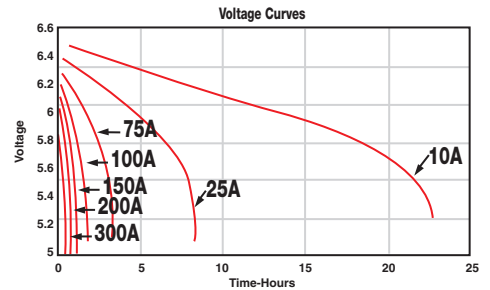
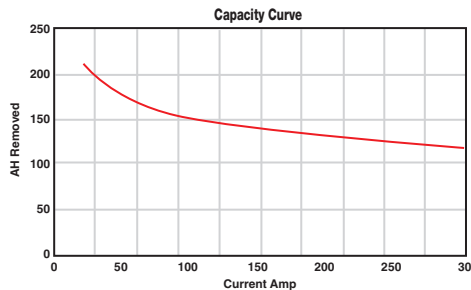

GNB Industrial Power – The Industry Leader.



GNB Industrial Power, a division of Exide Technologies, is a global leader in motive power battery and charger systems for electric lift trucks and other material handling equipment. With a strong manufacturing base in both North America and Europe and a truly global reach (operations in more than 80 countries) in sales and service, GNB Industrial Power is best positioned to satisfy your power needs locally as well as all over the world.

Based on over 100 years of technological innovation, the Motive Power group leads the industry with the most recognized global brands, such as GNB® FLOODED CLASSIC®,

TUBULAR-HP®, ELEMENT®, LIBERATOR®, GNB® FUSION™, ELEMENT® GEL, and SONNENSCHWEIN®. They have come to symbolize quality, reliability, performance and excellence in all the markets served.

GNB Industrial Power takes pride in its commitment to a better environment. Its Total Battery Management program, an integrated approach to manufacturing, distributing and recycling of lead acid batteries, has been developed to help ensure a safe and responsible life cycle for all of its products.

GNB Industrial Power

USA – Tel: 877.462.4636

Canada – Tel: 800.268.2698

www.gnb.com

GB4086 2012-06

